

# OWNERS MANUAL



The New Wave of Energy Efficient Heat



[WWW.SUNCLOUD.COM](http://WWW.SUNCLOUD.COM)

**PLEASE READ THIS MANUAL BEFORE OPERATION**

## TABLE OF CONTENTS

Welcome .....	2
1. Introduction .....	3
2. Benefits.....	4, 5
3. Care/Maintenance .....	6
4. Operation.....	6
5. Lamp Inspection .....	7
6. Filter Maintenance .....	7
7. Performance Suggestions .....	8
8. Replacement Parts .....	9
9. Warranty Information .....	10

[www.suncloud.com](http://www.suncloud.com)

## WELCOME

Congratulations! You have made a choice for comfortable, safe heat. Your purchase of a Solar Comfort by Sun Cloud, a most efficient zone heating system, is a quality investment.

Solar Comfort by Sun Cloud will provide safe, comfortable and economical heat. Solar Comfort's unique infrared lamps produce no fumes or deadly monoxides—it is truly clean heat!

All of the ambient air processed through the Solar Comfort pass through a lifetime washable filter. The Solar Comfort circulates and recycles heated air at a low level thus producing warmth at floor level and even heating.

With proper care and operation, this new Solar Comfort zone heating system will provide a better, more comfortable environment for years to come.

Experience the difference in Solar Comfort soft heat. IT JUST FEELS GOOD!

Sun Cloud Inc.

## 1. INTRODUCTION

The Solar Comfort by Sim Cloud infrared heating system is a revolutionary concept offering more efficient heat at less cost. Solar Comfort's impressive air quality and effective heating performance are the result of an innovative system design using absorption of infrared energy by a unique heat exchanger to produce, mix, circulate and recycle heated air at the proper location. The resulting even distribution minimizes heat loss at walls, windows, and ceilings; saving heat, energy, and money! This system heats air in much the same way that the sun heats the earth and its atmosphere by means of safe infrared absorption-hence the name Solar Comfort.

UNLIKE kerosene, gas, or wood heating which must have excessive ventilation, (cold air coming into the house) the Solar Comfort permits the structure to be closed for efficient heating with no danger of monoxide poisoning or asphyxiation.

Solar Comfort heaters are equipped with a lifetime washable static filter system which will remove airborne particles as the air is pulled into the Solar Comfort heating system.

The Solar Comfort is constructed of lifetime galvanized steel, copper and aluminum metals.

## **2. BENEFITS**

### **2A. SAFETY**

Extensive testing has verified the safety of the Solar Comfort zone furnace. Safe, clean, infrared lamps provide the heat; there is no combustion or fumes.

Due to its safe operating temperature, the Solar Comfort may be placed next to flammable materials with no safety clearance needed. The Solar Comfort heating system has been approved for zero clearance and A-1 INSURANCE rating! This highest safety rating means lowest possible insurance costs.

The Solar Comfort will not burn or create a fire hazard; complete safety is number one for all, including small children.

### **2B. ECONOMY**

The unique Solar Comfort by Sun Cloud process virtually prevents the wasteful air layering of conventional systems. The heat does not accumulate near the ceiling.

By using individual controlled units the Solar Comfort system provides heat only where and when it is needed. Zone heating—Economical heating.

Solar Comfort zone heating is less expensive per heated square foot and requires no expensive duct installation, therefore, no heat is lost every time the unit runs. The Solar Comfort uses standard 110 volt household current, no special 220 volt wiring or chimney vent.

The Solar Comfort has lower operating and maintenance costs. There is only one moving part, the fan motor, and is equipped with quality trouble free controls. There are no burners to rust, corrode or adjust; no pilot light to waste energy. Safe, clean, long-life infrared lamps provide the heat energy and are replaced easily and inexpensively. (Average lamp life is 5000+ hours or approximately 3-5 years). The Solar Comfort is constructed of lifetime metals, copper, galvanized steel and aluminum.

## **2C COMFORT**

The Solar Comfort provides even heat distribution and warmer floors. The Solar Comfort thermostatically controls, circulates and recycles heated air at the floor for maximum use and comfort. The floor to ceiling temperature differential is minor.

Solar Comfort zone heating does not remove humidity from the air, it actually helps to maintain humidity levels. Water does not readily condense on windows as with conventional systems. Even heating and humidity provide more comfort at lower heat settings with less static electricity.

As the Solar Comfort operates, you will notice that its heating ability does not depend on a high-speed flow of air. Instead, its gentle airflow promotes more effective heat mixing action and air stability at the floor. Soft heat.

The Solar Comfort does not burn, dry out or otherwise pollute the air with impurities. This protects the humidity level and air quality important to health and breathing comfort.

## **2D. CLEAN AND CONVENIENT**

Solar Comfort has no messy tanks to fill, wicks to clean, wood to hassle, ashes to carry and leaves no soot film on walls and drapery. The Solar Comfort is convenient to use, just plug it in to any 110 volt receptacle.

## **3. CARE/MAINTENANCE**

### **CABINET CARE**

To maintain the furniture quality cabinet use any commercial dusting or polishing product.

### **FILTER CARE**

See filter maintenance in Section 6.

## **4. OPERATION**

Plug the power cord into any 110 volt 15 amp receptacle. Turn power switch (located in the rear of the unit) to the "On" position and set the thermostat to the desired temperature. The four infrared heating lamps will come on. In about one minute the fan will come on delivering heat.

## **5. LAMP INSPECTION**

### **5A. TO VISUALLY INSPECT THE LAMPS**

Turn the thermostat up until the lamps come on, remove the filter and look through the screen at the rear of the unit. Looking past the fan blades, all four lamp bases should be glowing.

### **5B. TO REPLACE A LAMP/LAMPS**

Remove the metal unit from the wood cabinet by removing the retainer located at the base of the wood cabinet. Next, remove the four screws in the lid (figure 1). Remove the inner cabinet (figure 2). (Parts 2,3, and 4: the inner cabinet, air chute, and heat exchanger all function as one piece.) Remove the defective lamp by unscrewing counter clockwise and replace with a new lamp. To complete the process, reverse the above steps.

For all other parts replacement contact your nearest authorized dealer.

## **6. FILTER MAINTENANCE**

### **POLYTRON STATIC FILTER SYSTEM**

Solar Comfort by Sun Cloud comes equipped with a washable Polytron static filter which is easy to clean. The manufacturer recommends the filter be cleaned once a month or as needed. To do this, follow these steps:

1. Remove the filter from the rear of the unit by tilting out.
2. Run warm tap water over the filter, the opposite direction of airflow, until sufficiently clear of dirt and dust. A small amount of mild detergent may be used.
3. Replace the filter to the rear of the unit

## 7. PERFORMANCE SUGGESTIONS

To assure maximum performance of the Solar Comfort by Sun Cloud heating system, please note the following recommendations:

1. For maximum efficiency, locate the Solar Comfort on an inside wall., exhausting toward the outside wall.
2. If the Solar Comfort is used in an area with bare concrete floors, position the unit a minimum of three feet above the floor.
3. For maximum efficiency, do not locate the Solar Comfort in an area with a high rate of air filtration.
4. To insure maximum efficiency, a 40% (minimum) relative humidity should be maintained in the heated environment.
5. The Solar Comfort is designed to operate for maximum efficiency up to the 70-72 degree range.
6. When the Solar Comfort is placed in an isolated area, i.e. basement, recreation area, the delivery registers and return air grills of the existing system should be closed in that area if possible.
7. For efficiency, the Solar Comfort is not recommended for areas with exposed, uninsulated concrete or metal walls.

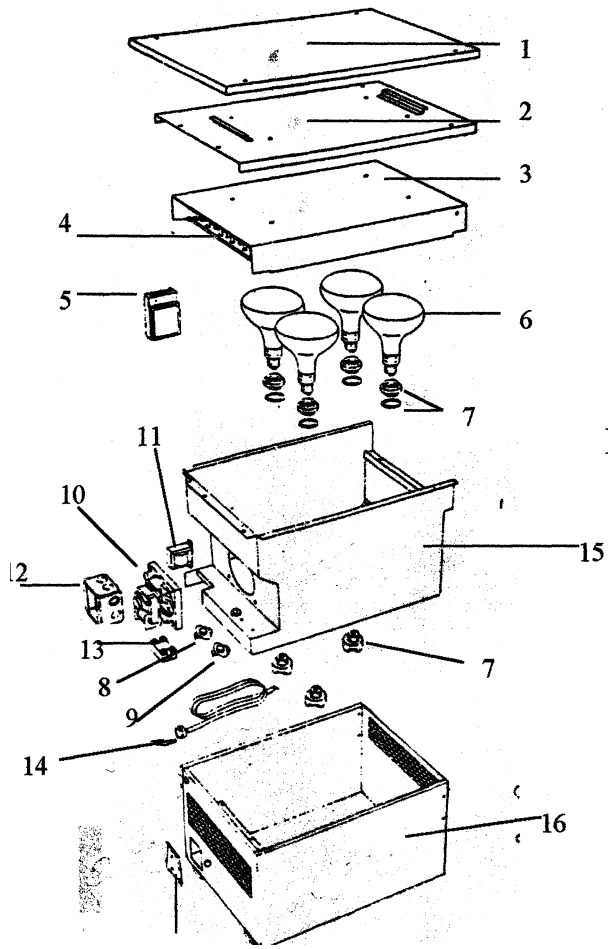

## REPLACEMENT PARTS

KEY	PART#	DESCRIPTION
1	—	Outer cabinet lid
2	—	Inner cabinet lid
3	—	Air chute
4	30000	Finished heat exchanger
5	40000	Thermostat-24 volt
6	48000	375 watt R-40 bulb
7	48100	Ceramic bulb receptacle
8	68015	High limit switch
9	39015	Fan control switch
10	—	Fan
11	—	Transformer
12	41015	J-box
13	36000	Relay
14	50100	Power supply cord
15	—	Inner housing
15	—	Outer housing
17	42015	J-box cover

**THREE YEAR LIMITED WARRANTY**

CUSTOMER NAME \_\_\_\_\_ MODEL # \_\_\_\_\_  
ADDRESS \_\_\_\_\_ SERIAL # \_\_\_\_\_  
\_\_\_\_\_  
DATE PURCHASED \_\_\_\_\_  
DEALER NAME \_\_\_\_\_ PHONE # \_\_\_\_\_

Sun Cloud Distributors, Inc. will repair or replace any defective part or component of any unit for a fall three- (3) year period.

The obligation of Sun Cloud Distributors, Inc. under this warranty is limited to furnishing at Sun Cloud Distributor's option, a new or rebuilt component or part which becomes defective during the warranty period from the date of sale. This warranty does not include the furnishing of any labor required to diagnose the necessity for replacement or repair or labor to remove or install any such part or parts. Nor does it include responsibility for any transportation expenses or any damages or loses incurred in transporting the unit to an authorized servicing dealer.

A factory-authorized dealer must perform warranty service. All services will be provided during normal business hours.

Owner's responsibilities include providing normal care and maintenance, proof of purchase and the owner shall be responsible for any expense for delivery to and from the authorized dealer.

Warranty is void if; the serial plate is defaced, defect is due to damage, product alteration, connection to an improper electrical supply, act of god, or where product has been abused, or where the product has been improperly installed, and not used in accordance with the Owners Manual. Sun Cloud Distributors shall not be responsible for any incidental or consequential damages.

Sun Cloud Distributors, Inc., 6124 Johnson **Drive**, Mission, KS 66202